



GUIDE TO GRADED ROOFING BATTENS



INTRODUCTION

As a highly competent roofer, you'll know that all roofing battens, must conform to BS 5534. This leaflet will inform you how to recognise what a full BS batten looks like - and what markings it should have on it.

THE BATTEN STANDARD

The British Standard which contains the rules that slating and tiling battens need to be graded to is...

BS 5534:2014+A2:2018

TIMBEREX GRADED BS5534 IMPORTED 25x50 CATG 2314

How to spot counterfeit roofing batten and identify a true graded batten

TIP ONE SIZING

- ✓ Check batten **isn't undersize** on both the thickness and the width
 - Minimum 25mm on the thickness, and to a maximum 28mm (allowed tolerances -0mm/+3mm)
 - Minimum 35mm to a maximum of 41mm for 38 mm sized batten
 - Minimum 47mm to a maximum of 53mm for 50mm sized batten
- ✓ Good graded batten will be **consistently sized** in both thickness and width, and at a minimum with allowed tolerances

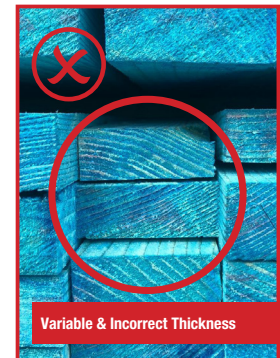



MARKINGS

Counterfeit batten may still be stamped, however with missing/incorrect markings.

Check to ensure the marking/stamping on each piece of batten shows...

- ✓ **Supplier** (Manufacturer)
- ✓ **Origin** - Imported and/or species code (either is permitted)
- ✓ **'Graded BS 5534'** (must state both graded and BS 5534)
- ✓ **Size** (25x38 or 25x50)
- ✓ Those companies who follow industry best practice recommended by NFRC/TDUK will also apply **3rd party accreditation markings** which records independent compliance and management records of the production of graded battens



DUE DILIGENCE

All documentation should show the following as a minimum, e.g. on delivery notes.

- ✓ Name of supplier
- ✓ Origin (imported and/or species code)
- ✓ Graded in accordance with BS 5534
- ✓ Basic size or sizes
- ✓ Type of preservative and method of treatment, if applicable (the vast majority of batten required is specified and needs to be treated - so the preservative and method should be shown)

Good suppliers also state, and should also offer, the following.

- ✓ Full Chain of Custody, e.g. FSC. Ask for our FSC®-certified products.
- ✓ As well as showing imported, good suppliers also state the species name within their documentation
- ✓ 3rd Party Accreditation (their ID markings/who it is)
- ✓ Use Class information (BS 8417 preservative treatment)
- ✓ Paperwork may also contain useful information such as confirmation of treatment by the UK WPA benchmark scheme



KNOTS

- ✓ Check **size of knots** on each face - 38mm / 50mm part of the batten
- ✓ **Max 5mm knot rule**, this is for knots running edge to edge, thickness only (see below)
- ✓ **Wane** permitted on one arris only - should not exceed one third of the batten dimension
- ✓ **Bow, spring or twist** should each be not greater than 5mm, measured over a length of 1.2m
- ✓ **Moisture content** of the batten should not exceed 22% at time of fixing (heavy batten may indicate wrong moisture content)

5mm Rule

Knots over 5mm running through the batten edge to edge (25mm) is not compliant with BS 5534.



'Through' edge knot greater than 5mm in diameter



'Through' edge knot less than 5mm in diameter



Edge knot running across face: greater than 5mm on an edge

More than half size on both faces (widths) of the batten

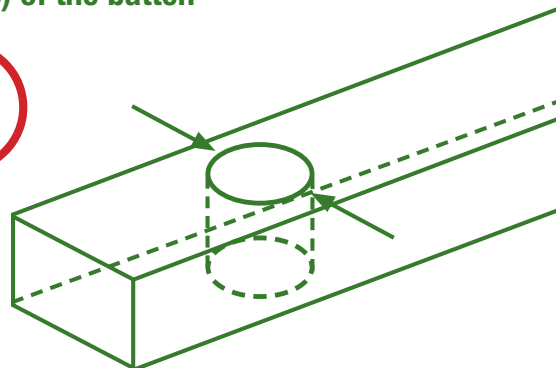

Less than half size on both faces (widths) of batten

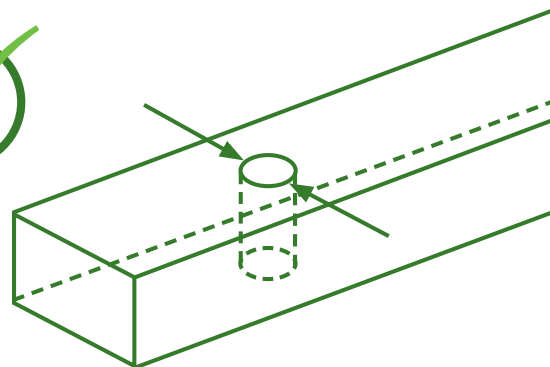

The rule on knots can be quite complicated, but essentially, any large knot which is bigger than half the width of the batten, appearing on both sides of the face (width), as illustrated above, would not be compliant to BS 5534.

Knots which are less than a palms width apart, best practice should be to take both knots into consideration as one overall knot, when assessing the knot size is within tolerances of BS 5534.

SOME OTHER HELPFUL THINGS YOU SHOULD KNOW...

Battens should be fixed by nailing to each rafter; but if any length of batten is shorter than about 1.2 metres – or it is insufficiently long enough to span over a minimum of three rafter supports, whichever is the greater – then it should not be used.

If any of your battens should have wane, it should be within allowed tolerances of BS 5534 (wane is permitted on one arris, (edge or corner), and should not exceed one third of the dimension of each of the faces on which it occurs). Even if your batten has wane and is within the allowed tolerances, good practice is to turn the batten over and nail it wane side down: thus leaving a full square edge on which to fix the slates or tiles.

Handling Precautions

You should have received the treated timber in a drip-free condition with no sign of preservative fluid on the surface. If this is not the case, the timber should be stored open stacked under ventilated conditions and protected from rain and snow to dry before use. When working with treated timber, wear gloves to protect the skin against abrasions and splinters. Any cuts and abrasions should be protected by a waterproof dressing. When power-sawing and machining, wear goggles to protect the eyes from flying particles. Wear a dust mask and, whenever possible, perform these operations outdoors to avoid accumulations of airborne sawdust or use a suitable dust extraction system around any mechanical saw or planing machine. Avoid frequent or prolonged inhalation of sawdust. Consult local regulatory authorities for further information on workplace exposure limits for wood dust. In order to prevent injury, care should be taken when lifting or moving timber. These handling precautions equally apply to untreated and treated timber.

Transportation, Storage & Disposal

It is recommended batten should be transported using an RHA approved hauler and that timber is checked prior to offloading for any forklift damage. It is recommended that all treated timber should be stored in dry conditions, treated timber should not be stored in either standing or submerged in water. Mould growth can and does occur on the surface of many products, including treated or untreated wood, during prolonged surface exposure to excessive moisture conditions. To remove mould from treated wood surfaces, wood should be allowed to dry. Typically, mild soap and water can be used to remove remaining surface mould. Safe Disposal of all treated wood should be carried out responsibly through an authorised waste contractor.

Personal Hygiene

After handling or working with treated timber, all exposed skin should be washed before commencing other activities, especially eating, drinking, smoking or going to the toilet. If sawdust accumulates on clothes, clean them before reuse. Launder heavily soiled clothes separately from other household wash items.

Recommended Minimum Timber Batten Sizes

(Roofing and Vertical Work)

APPLICATION	BASIC MINIMUM SIZE OF BATTENS			
	up to 450mm Span		up to 600mm Span	
	Width mm	Depth mm	Width mm	Depth mm
SLATES (double lap)				
Natural - sized or random	50	25	50	25
Fibre-cement or concrete	38	25	50	25
CLAY and CONCRETE TILES				
Double lap	38	25	38	25
Single lap	38	25	50	25

Notes

- Tolerances on basic sizes: width +/-3mm; depth -0, +3mm; based on measurement at a reference moisture content of 20%.
- Where a batten is continuously supported directly by board sarking which is itself capable of supporting the roof imposed concentrated load (e.g. in Scottish practice), battens may be of a minimum size of 38mm x 19mm.
- Span is defined as the distance between centres of supports, or the clear distance between the face of supports plus half the bearing length at each end support, whichever is the lesser. The minimum end bearing length should be 17.5mm.
- Battens for spans greater than those given in Table 1 for other slates, tiles and shingles such as timber shingles and shakes or metal tiles, or other proprietary roofing products should be in accordance with manufacturers' recommendations.
- Graded battens will be marked and accompanied by the identification information given in BS 5534. Batten sizes for rafter spans greater than 600mm should be designed by structural calculation in accordance with BS 5534 Annex F for strength and stiffness. When determining batten sizes, consideration should be given to adequate dimensions for nailing and using commercially economic sizes.
- Where specific batten sizes are specified for fixing only of ridge, hip capping and also valleys, these should be followed in those locations. They should not be used for general areas.
- For counter battens used in conjunction with insulation installed over rafters see BS 5534 Annex B.
- Nails for use with battens, counter-battens and boarding (board sarking) should conform to BS EN 10230-1. For extra protection and in coast regions, they should be coated by zinc or zinc alloy coating methods specified in BS EN 10230-1.

Note: Timber containing copper based preservative can cause corrosion of uncoated mild steel nails in the presence of moisture.

WHY SHOULD YOU USE SR TIMBER PREMIUM GOLD BATTENS?

Correctly graded roofing batten to BS 5534

- ✓ **A trusted trademarked brand:** Our unique and distinctive gold colour. Peace of mind you are installing and working with a British Standard product
- ✓ **Relevant standards:** BS 8417:2011+A1:2014 (Preservation of Wood) and BS 5534:2014+A2:2018*
- ✓ **Third party accreditation** regularly audited by CATG (UKAS Accredited) to ensure continued and consistent application of British Standards.
- ✓ **Full to size:** Batten thickness minimum 25mm (allowed tolerances -0mm/+3mm). Batten width 38mm or 50mm (allowed tolerances -3mm/+3mm). Gold batten will be consistent in dimension.
- ✓ **Full Chain of Custody certification FSC.** Ask for our FSC®-certified products
- ✓ **Vacsol® 6118 Aqua Preservative,** treated to BS 8417:2011+A1:2014* Impregnated to Use Class 2 by double vacuum/low pressure water based preservative. Protection with a standard 60 year service life against insect attack and wood rotting fungi. (When used correctly and installed above dpc level in buildings.)
- ✓ **Product stamped showing:** Producer, Graded BS 5534, Imported, Size, CATG (our 3rd party independent accreditation marking)
- ✓ **Wood Protection Association:** WPA Quality Approval Certification Audited as an approved treater and capable of producing treated wood to the correct Use Class(es). Use class of treatment is stated on a all documentation
- ✓ **Each delivery is accompanied with documentation stating:** Supplier, imported, graded in accordance with BS 5534, sizes, type of treatment

- ✓ **Factory graded roofing battens:** We control by; firstly, automated and visual grading of the raw material, the second process is actually grading every piece of produced batten at commercial speed - grading consists of checking dimensions, knot sizes, wane, fissures and splits, slope of grain, rate of growth, distortion, decay, insect attack and sap stain, are all within the requirements set out in BS 5534. Grading the finished batten dimensions, 25x38 and 25x50 is the correct process to follow, buying good raw material and then just re-cutting batten dimensions from it without final grade of the finished product is not the correct method of grading a roofing batten dimension. SR Timber's Premium Gold roofing batten is piece graded - every single piece, by qualified, independently trained graders. Grading every finished piece of produced batten double checks for; dimension issues, knots outside tolerances, wane - if any are to requirements, fissures and splits are checked to be ok and that none have been missed at raw material grading stage, distortion is checked ensuring non is outside of requirements, ensuring no signs of decay and insect attack, and sap stain within guidance - if any seen.
- ✓ **Kiln dried to the correct levels:** Firstly ensuring the timber is at the correct moisture content to enable the treatment process works correctly, then the final product - graded roofing batten, will be treated correctly and will conform to BS 8417 - having sufficient treatment within the material to Use Class 2, and giving a 60 year service life. By kiln drying timber, it assists and greatly reduces possible shrinkage/movement of the finished product - roofing batten when fixed to the roof. With SR Timber Premium Gold being kiln dried to the correct moisture levels and then treated correctly, any possible dimensional shrinkage still within the BS 5534 guidelines will be to a minimum, if any, at all - each finished roofing batten product will be consistent in dimension. Using battens which are not kiln dried to correct moisture levels greatly increases incorrect moisture content prior treatment - which means correct treatment is questionable, it is also likely that roofing batten not dried correctly will shrink - and likely shrinking excessively, upon excessive shrinkage of battens, its likely the roof coverings nailed to the batten would become loose, meaning that the roof coverings become extremely vulnerable to be blown off the roof in any bad weather, high winds.



For more information, speak to the SR Timber team today

*See product datasheet for more information at: sr-timber.co.uk/Product/sr-timber-premium-gold-roofing-batten



SR Timber, Nunn Brook Road, Huthwaite,
Sutton-in-Ashfield, Nottinghamshire. NG17 2HU

T: 01623 446 800

E: sales@sr-timber.co.uk www.sr-timber.co.uk

**Our passion is timber and delivering
the best possible product**



All rights reserved. No part of this publication may be reproduced or transmitted in any form, or by any means, electronic or mechanical including photocopy, recording or any information storage and retrieval system, without permission in writing from SR Timber. No information contained within this publication can be used to compile any other printed or electronic directory or mailing list. Whilst every effort has been made to ensure accuracy, the publisher does not, under any circumstances, accept responsibility for errors or omissions and no representation or warranty is made in relation to the suitability of a product for a specific application. Visuals are for illustration purposes only. E&OE.

SRTDL0624 V7 | © SR Timber 2024. All rights reserved.