

# Grovebury

A concrete interlocking tile that offers the classic, gentle flowing lines of a traditional pantile, but with the added benefit of a double pantile shape for quicker and easier installation than a single pantile design.

## KEY ADVANTAGES

- Traditional double pantile profile.
- Single lap interlocking tile making it quick and easy to lay.
- Low pitch capability, as low as 15° at 100mm headlap.

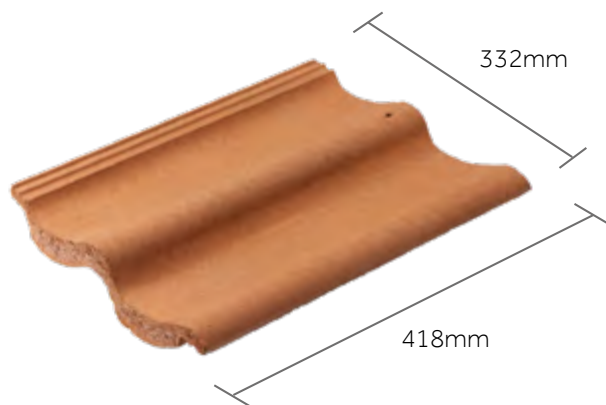

## PRODUCT DATA

<b>External Dimensions</b> (+/- 4mm)	418 x 332mm
<b>Minimum Pitch and Headlap</b>	15° at 100mm headlap / 17.5° at 75mm headlap
<b>Maximum Pitch</b> (subject to fixing specification and fire resistance requirements above 69°)	90°
<b>Maximum Headlap</b>	125mm
<b>Minimum Gauge/Batten Spacing</b>	293mm
<b>Maximum Gauge/Batten Spacing</b>	Below 17.5° at 318mm 17.5° and over 343mm
<b>Hanging Length</b> (+/- 4mm)	397mm
<b>Cover</b> (all figures are net & do not allow for wastage)	
Linear cover of 1 tile (+/- 5mm)	300mm
Covering capacity	10.5 tiles/m <sup>2</sup> at 318mm gauge 9.7m <sup>2</sup> at 343mm gauge
<b>Weight*</b>	
	50kg/m <sup>2</sup> at 318mm gauge 46kg/m <sup>2</sup> at 343mm gauge
per pallet, including pallet	1.08 tonnes
per 1000 tiles	4.75 tonnes
<b>Battens Required</b> (at max. gauge)	2.92lm/m <sup>2</sup>
<b>Batten Size</b>	
Rafter centres up to 450mm	38 x 25mm
Rafter centres up to 600mm	50 x 25mm
<b>Fixing Clips</b>	Eaves, Verge & Tile Clips
<b>Nail Size for Tiles</b>	70 x 3.75mm (A/A)**
<b>Pallet Quantities</b>	Tiles per pallet 216 Tiles per pack 36 Packs per pallet 6

\*All weights nominal \*\* (A/A) Aluminium Alloy

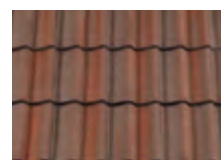

**Breckland Brown**  
Tile product code:  
**10003067**

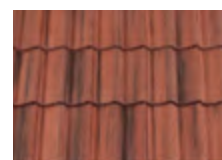

**Farmhouse Red**  
Tile product code:  
**10003066**

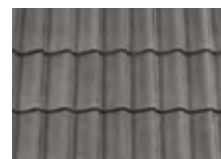

**Slate Grey**  
Tile product code:  
**10003063**

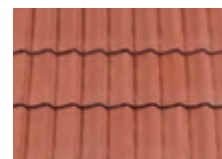

**Terracotta**  
Tile product code:  
**10003064**

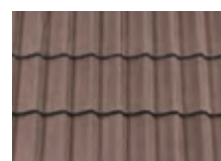

**Tudor Brown**  
Tile product code:  
**10003065**



**SCAN THE QR CODE**  
for more information  
or to order a tile sample

## INSTALLATION GUIDELINES:

- Tiles must be hung by their nibs.
- Tiles must be laid in a straight bond pattern.
- It is always advised that tiles are laid at mid shunt, although the precise roof details may require tiles to be laid with a more open or closed shunt.
- An Eaves Comb must be used in all eaves situations.
- Always use the FixMaster tool from the BMI Redland website to generate a project-specific BS 5534-compliant fixing specification.
- Both left-hand and right-hand perimeter tiles at the verge must have a secondary fixing as prescribed by BS 5534.
- Please see Redland Concrete Roof Tiles & Fittings - a Guide to Installation, Maintenance and Disposal, which is available for download from the BMI Redland website, for further information.

## PRODUCT STANDARDS

BMI Redland concrete tiles and slates are manufactured to BS EN 490 - Concrete roofing tiles and fittings for roof covering and wall cladding. Tolerances are set in line with BS EN 490. Tiles meet the requirements of BS 5534 - Code of practice for slating and tiling (including shingles), providing the BMI Redland FixMaster specification is followed.

## SAFETY, QUALITY & ENVIRONMENT

BMI Redland tiles are manufactured under a Quality Management System approved to ISO 9001 and an Environmental Management System approved to ISO 14001, by TÜV UK Ltd. Information regarding transportation, handling, storage and disposal can be found in Redland Concrete Roof Tiles & Fittings - a Guide to Installation, Maintenance and Disposal, which is available to download from the BMI Redland website.

## TECHNICAL SUPPORT

Whether you require telephone advice for your project, an online fixing specification or want to benefit from our complete guaranteed specification service, our expert team is on hand to help ensure success for your roof.

## FURTHER INFORMATION & TOOLS

For access to Declarations of Performance, product codes or for expert help and advice, please visit our website. Information is accurate at the time of printing. Product information, technical standards and codes of practice are under constant review. We reserve the right to change and amend product information without prior notice. For the latest information, suitability and specification advice, please refer to our website or contact Redland's Technical Services team for up-to-date product information.

## REDLAND TECHNICAL SERVICES

0330 123 4585

technical.redland@bmigroup.com

## REDLAND CUSTOMER SERVICES

0370 560 1000

sales.redland@bmigroup.com

### TILES

Standard Tile

Half Tile

### UNDERLAYS

Divoroll Elite 200 2S (1.5m x 50m)

Divoroll Air (1m x 50m)

ClimaTape (60mm x 25m)

### EAVES PRODUCTS

Rapid EavesVent 2-in-1 Tray (1m)

Rapid EavesVent Rafter Roll (6m x 800mm)

RedVent 25 Over-Fascia Vent (6m)

Underlay Support Tray (1.5m)

Eaves Comb Filler (1m)

### VERGE PRODUCTS

Cloaked Verge LH

Cloaked Verge RH

DryVerge (Pack of 18 LH &amp; 18 RH)

DryVerge Gable End Pack (1 gable)

### HIP PRODUCTS

Continuous Hip (5m)

Third Round Hip/Ridge Junction

Third Round Hip (without nail holes)

Third Round Hip (with nail holes)

Third Round Block-End Hip

Third Round Hip End Cap

Mortar Bedded Fixing Kit (5m)

### VALLEY PRODUCTS

GRP 125 Valley (3m)

Dry Valley (High Profile) (3m)

### ABUTMENT PRODUCTS

Top Edge Abutment Ventilation Pack (3m)

Wakaflex Rapid Flashing

Bonding Strip (High Profile) (3m)

### RIDGE PRODUCTS

DryVent Ridge (2.7m)

Continuous Ridge (5m)

Half Round Ridge

Half Round Block-End Ridge

DryVent Monoridge (2.7m)

Half Round Monoridge

Half Round Monoridge End Cap (Pair)

Mortar Bedded Fixing Kit (5m)

### VENTILATION TILES

Grovebury 8.8k ThruVent Tile

Flexible Pipe (100 to 100mm)

### FIXING PRODUCTS

Tile Clip (500 clips)

Verge Clip LH (50 clips)

Verge Clip RH (50 clips)

Eaves Clip inc Nail (100 clips)

Tile &amp; Tile Clip Nail (1kg = approx 650 nails)

Tile Nail (1kg = approx 460 nails)

Kro-Clip (50 clips)

Innofix Clip Red (250 clips)

**Note:** For a complete list of products that are compatible for use with this tile, please see the latest edition of the BMI Redland Pocket Guide, available to download from the website. Hard copies can be obtained by contacting the Redland Customer Services team.